

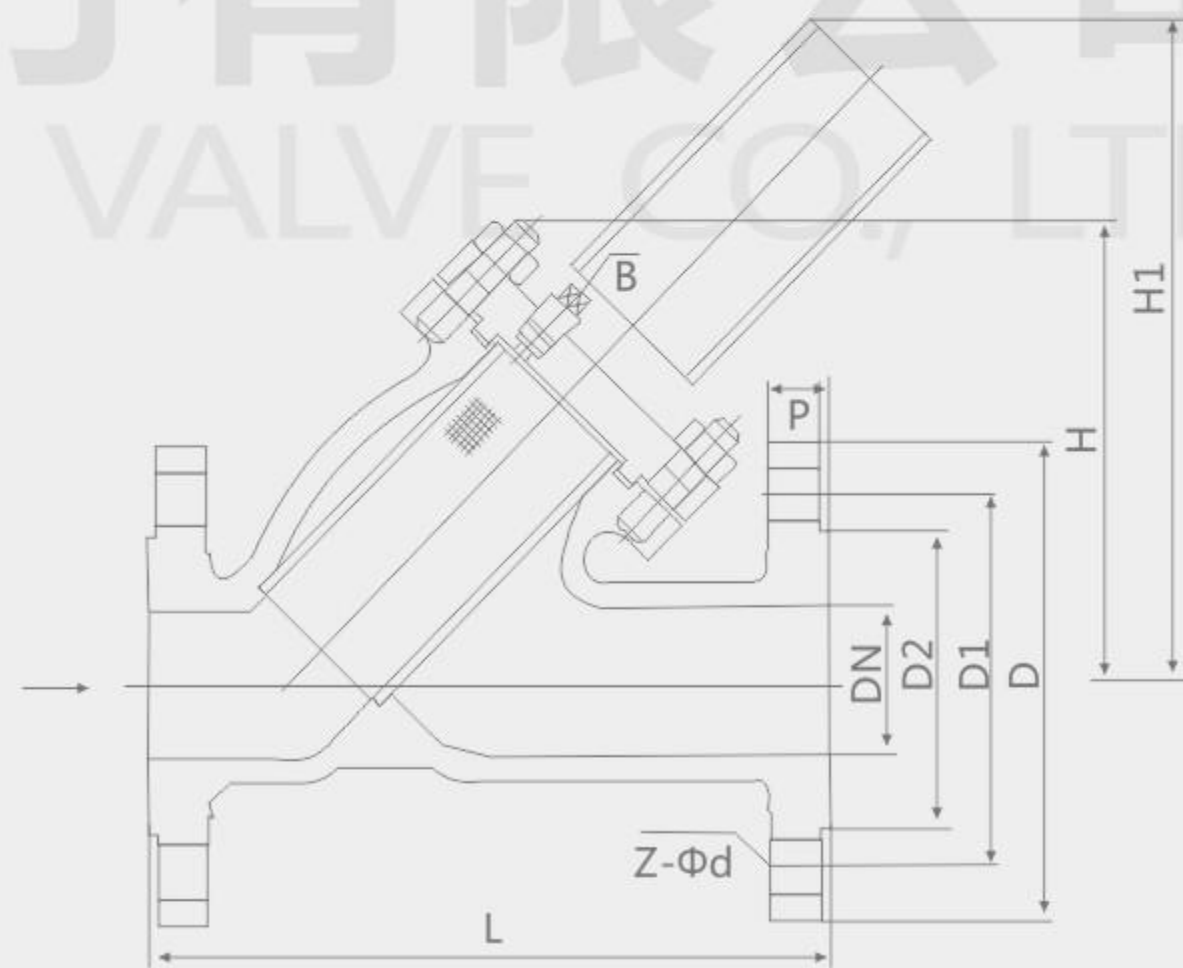

正南阀门有限公司
ZHENGAN VALVE CO., LTD

FILTER SERIES

过滤器系列



国标Y型过滤器

GB Y-type filter

GL41W-16C/P/R

产品概述 Products overview

Y型过滤器是输送介质的管道系统不可缺少的一种过滤装置, Y型过滤器通常安装在减压阀、泄压阀、定水位阀或其它设备的进口端, 用来清除介质中的杂质, 以保护阀门及设备的正常使用。Y型过滤器具有结构先进, 阻力小, 排污方便等特点。Y型过滤器适用介质可为水、油、气。一般通水网为18~30目, 通气网为10~100目, 通油网为100~480目。

Y type filter is the medium of pipeline system is indispensable to a filtering device, Y type strainer is usually installed in a reducing valve, relief valve and the inlet water valve or other equipment, used to remove the impurity in the medium, in order to protect the valves and equipment normal use. Y type filter has the advanced structure, small resistance and easy drainage, etc. Y type filter suitable medium for water, oil and gas. Generally water network are 18 ~ 30 mu, ventilation network are 10 ~ 100 mesh, oil network 100 ~ 480 mesh. Basket strainer is mainly

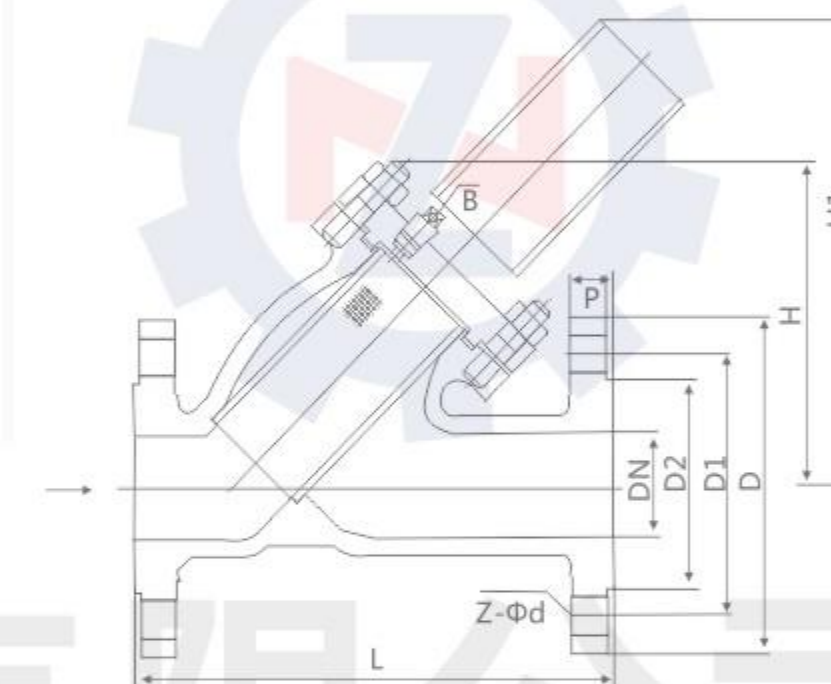

基本参数

介质温度: 300(°C)
工作压差: 2KG
材质: 不锈钢
产品别名: Y型过滤器
适用范围: 液体过滤
连接形式: 法兰
类型: 直角式
流动方向: 单向
适用介质: 水
压力环境: 常压

Basic parameters

Medium temperature: 300 °C
Working pressure difference: 2 kg
Material: stainless steel
Product alias: Y type filter
Scope of application: liquid filtration
Connection: flange
Type: the right Angle
Flow direction: one way
Applicable medium: water
Pressure: the atmospheric pressure

产品执行标准 Production enforce standard

产品规范 Product Specification	设计规范 Design Spec	结构长度 Face to Face	连接法兰 Flange End	试验与检验 Test & Check	产品标识 Marking	供货规范 Supply
	GB/T 21637	GB/T 12221	JB/T79	JB/T 9092	GB/T 12220	JB/T 7928

产品性能规范 Chief property and specification

型号 Type	连接方式 Conjunction method	公称压力 PN(MPa)	耐压试验压力 (MPa)	工作压力 (MPa)	壳体材料 Material	过滤网材料 Strainer material	网总面积
GL41H-10	法兰Flange	1.0	1.1	1.0	不锈钢 Stainless steel	不锈钢 Stainless steel	3~4DN
GL41H-16	法兰Flange	1.6	1.76	1.6	球墨铸铁 Ductile cast iron		
GL41H-25	法兰Flange	2.5	2.75	2.5	碳钢 Carbon steel		

国标Y型过滤器

GB Y-type filter

主要零件材料 Material for main parts

零件名称 Parts Name	零部件材料 Part Material					
阀体/阀盖 Body/Bonnet	25	WCB	CF8	CF8M	CF3	CF3M
网架 Dis/stem	25	35	1Cr18Ni9Ti	1Cr18Ni12Mo2Ti	00Cr18Ni10	00Cr17Ni14Mo2
滤网 Strainer	1Cr18Ni9Ti		1Cr18Ni9Ti		00Cr18Ni10	
垫片 Gasket	18-8柔性石墨 18-8/Flexible Graphite					
螺栓 Bolt	35		1Cr17Ni2		1Cr18Ni9Ti	
适用温度 Suitable temp	-29~+425°C		-40~+200°C		-40~+200°C	
适用介质 Suitable medium	水、油品、蒸汽 Water, Oil, Steam		硝酸类 Nitric Acid		醋酸类 Acetic Acid	

尺寸 Dimensions PN16

Unit:mm

Nominal Diameter	L	d	D2	D1	D	b	f	n-φd1
15	130	15	45	65	95	14	2	4-14
20	150	20	55	75	105	14	2	4-14
25	180	25	65	85	115	14	2	4-14
32	165	32	78	100	135	16	2	4-18
40	200	40	85	110	145	16	2	4-18
50	220	50	100	125	160	16	3	4-18
65	250	65	120	145	180	18	3	4-18
80	280	80	135	160	195	20	3	8-18
100	320	100	155	180	215	20	3	8-18
125	340	125	185	210	245	22	3	8-18
150	385	150	210	240	280	24	3	8-23
200	480	200	265	295	335	26	3	12-23
250	545	250	320	355	405	26	3	12-26
300	605	300	375	410	460	28	3	12-26

美标/日标Y型过滤器

API/JIS Y-type filter

尺寸 Dimensions CLASS 150

Unit:mm

Nominal Diameter	L	d	D2	D1	D	b	f	n-φd1
15	120	15	35	60.3	90	12	2	4-16
20	140	20	43	70	100	12.5	2	4-16
25	150	25	51	79.4	110	12.5	2	4-16
32	170	32	63.5	88.9	115	13.2	2	4-16
40	190	40	73	98.4	125	14.8	2	4-16
50	215	50	92	120.7	150	16.3	2	4-19
65	205	65	105	139.7	180	17.9	2	4-19
80	285	80	127	152.4	190	19.5	2	4-19
100	300	100	157	190.5	230	24.3	2	8-19
125	350	125	185	216	255	24.3	2	8-22
150	380	150	216	241.3	280	25.9	2	8-22
200	480	200	270	298.5	345	29	2	8-22
250	545	250	324	362	405	30.6	2	12-25
300	605	300	381	431.8	485	32.2	2	12-25

尺寸 Dimensions 10K

Unit:mm

Nominal Diameter	L	d	D2	D1	D	b	f	n-φd1
15	120	15	51	70	95	12	1	4-15
20	140	20	65	75	100	14	1	4-15
25	150	25	67	90	125	14	1	4-19
32	170	32	76	100	135	16	2	4-19
40	190	40	81	105	140	16	2	4-19
50	215	50	96	120	155	16	2	4-19
65	250	65	116	140	175	18	2	4-19
80	285	80	126	150	185	18	2	8-19
100	300	100	151	175	210	18	2	8-19
125	350	125	182	210	250	20	2	8-23
150	380	150	212	240	280	22	2	8-23
200	480	200	262	290	330	22	2	12-23
250	545	250	324	355	400	24	2	12-25
300	605	300	368	400	445	24	3	16-25